

Wintec uses an Allen Bradley SLC 500 with an Allen Bradley Servo drive. A NEMA 4X cabinet is Mounted remote housing the processor, I/O, Drive, Panel View 300, E-Stop, and 110V 30 amp Disconnet.

Outfeed Conveyor use 6" wide Intralox 2400 Series Acetal Belt Drive Package consists of a Baldor Motor and Gear Reducer with an Allen Bradley PowerFlex4 230/480V 3 ph enclosed in a NEMA 4X Enclosure with E-Stop and Start/Stop PB

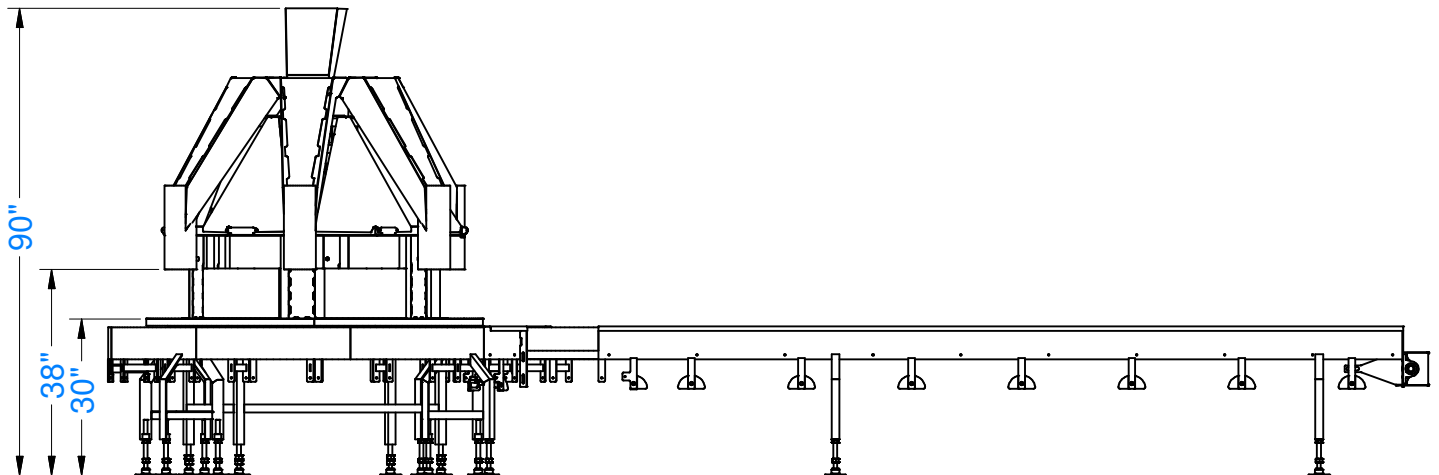
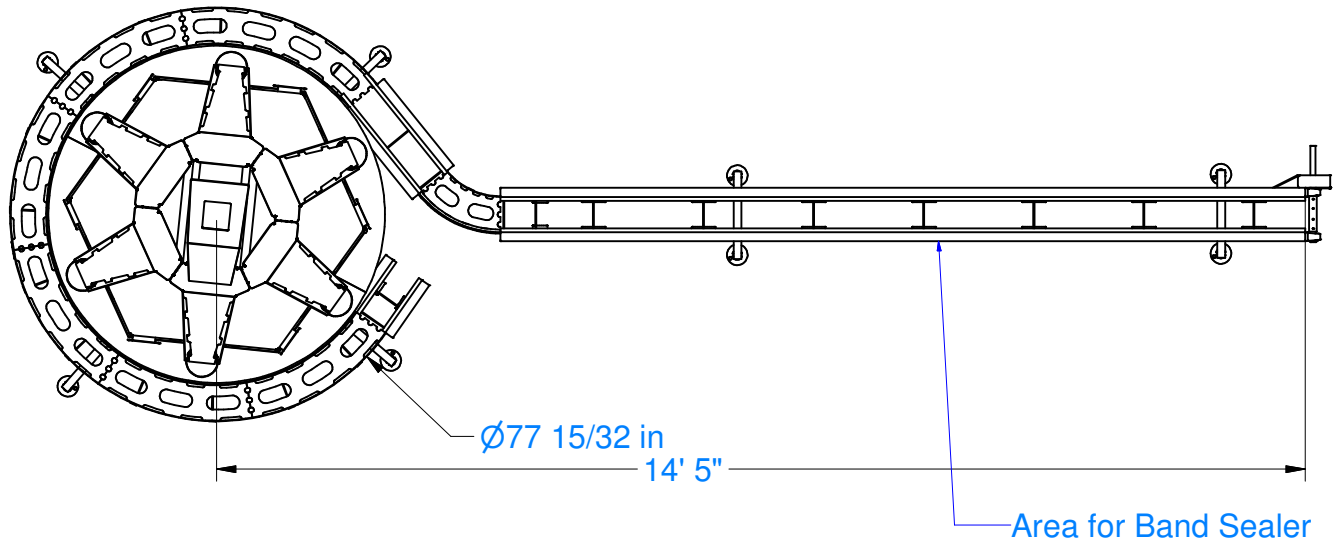

TITLE  
**Wintec 6 Servo  
 6 Station Bagging Machine**

THIS DRAWING INCLUDING THE PRINCIPLES OF DESIGN, IS SUBMITTED WITH THE AGREEMENT THAT IT IS NOT TO BE REPRODUCED, COPIED, OR LOANED IN PART OR WHOLE. IT IS NOT TO BE USED IN ANY MANNER THAT MAY CONSTITUTE A BETRIMENT DIRECTLY OR INDIRECTLY TO NORTHWIND, INC.

DRAWN  
 Mark Ogier  
 APPROVED

DATE  
 6/27/2006

SIZE C	Wintec 6_SingleConveyor	REV
SCALE	SHEET 1 OF 1	